

# 1 Parts description

Visit operation detail at Super B

Website: <http://www.superbiketool.com/>

Click Product ➔ Frame & Fork ➔ 4. ➔ TB-1945

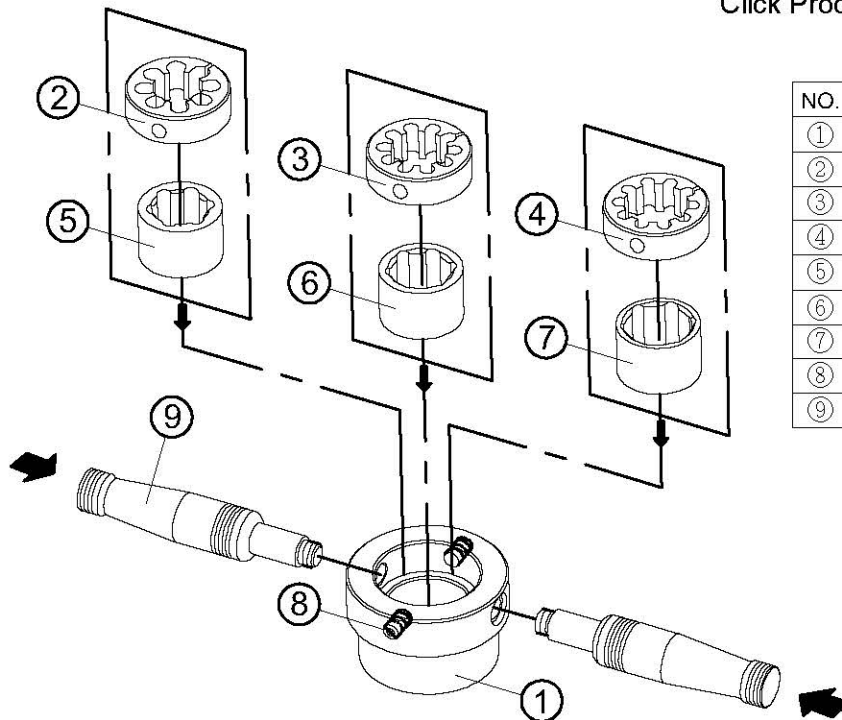

NO.	PART	Q'TY
①	Body	1
②	Cutting die 1"X24TPI (TB-945A)	1
③	Cutting die 1-1/8"X26TPI(TB-945B)	1
④	Cutting die 1-1/4"X26TPI(TB-945C)	1
⑤	Cutting guide 1" (TB-945D)	1
⑥	Cutting guide 1-1/8" (TB-945E)	1
⑦	Cutting guide 1-1/4" (TB-945F)	1
⑧	Adjustment screw	2
⑨	Handle	2

# 2 Assembly

Rotate the two handles ⑨ into the body ① by following the direction of indicator.

# 3 Instruction

1. Must wear goggles to avoid any danger before using the fork threading set.
2. TB-1945 is only used to chasing existing thread on the fork steerer, using on the threadless fork is not allowed.
3. To measure the fork steerer size before using, put the right size of cutting die and guide into the body ①. Make sure the notch of cutting die fix adjustment screws ⑧, and then screw both side of adjustment screws ⑧ lightly. (Max 1.0Nm) (see picture 1)
  - 3-1. 1" fork steerer threaded by cutting die (TB-945A) ② and cutting guide (TB-945D) ⑤.
  - 3-2. 1-1/8" fork steerer threaded by cutting die (TB-945B) ③ and cutting guide (TB-945E) ⑥.
  - 3-3. 1-1/4" fork steerer threaded by cutting die (TB-945C) ④ and cutting guide (TB-945F) ⑦.
4. Add cutting oil on the thread of fork steerer. (see picture 2)
5. Put the fork threading set onto the fork steerer, lightly (without downward pressure) rotate the handle clockwise until the die engages the thread of the fork steerer. (see picture 2)
6. Must follow principal of two forward and one backward when cutting, and continue to add cutting oil. (choose the proper cutting oil to avoid any damage of die and thread) (see picture 3)
7. Remove the TB-1945 by turning counter-clockwise after cutting.
8. Clean the cutting oil and chips on tool set and fork, and coat anti-rust oil on tool set and fork to make sure that the cutting die and fork durability.

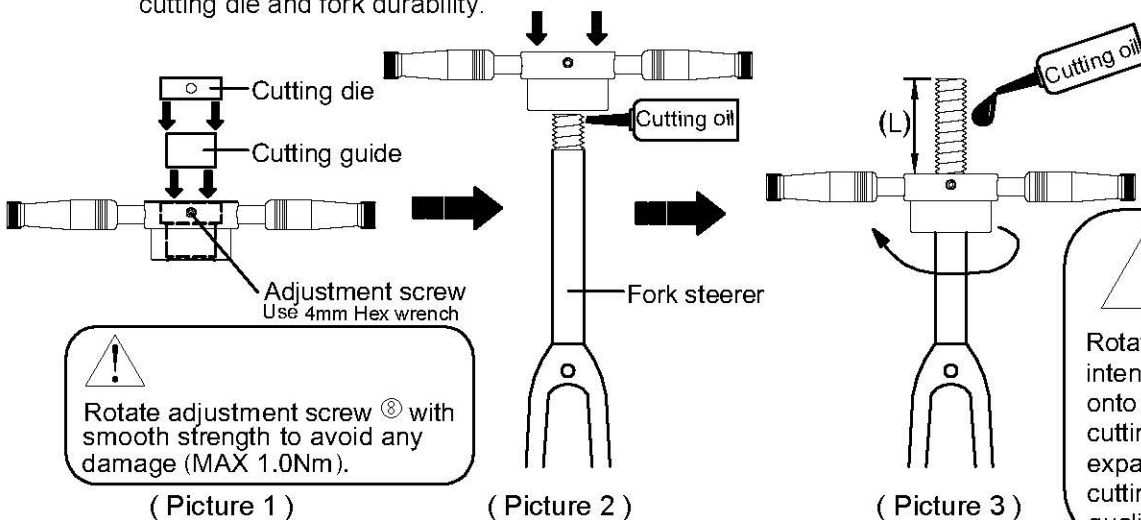

**!**  
Rotate for shaving and cutting, intend to drop the cutting oil onto the fork thread set and cutting die, that purpose of expandable life cycle for cutting die, and promote the quality work of thread fork set.

## 1 零件名稱及數量

詳細操作影片請至Super B官網  
<http://www.superbiketool.com/> 觀看，點擊  
Product ➡ Frame & Fork ➡ 4. ➡ TB-1945

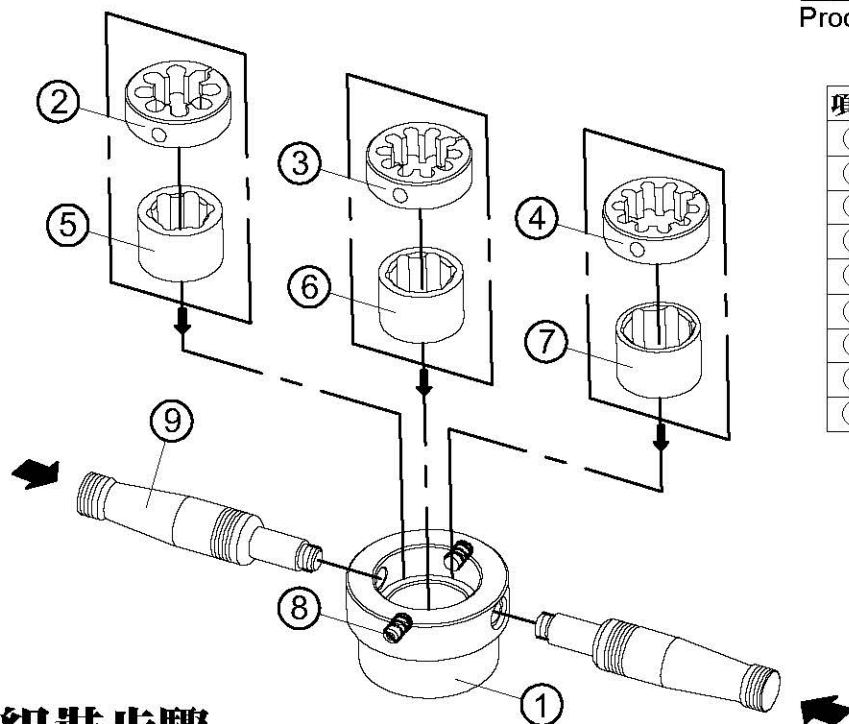

項次	名稱	數量
①	主體	1
②	牙刀 1"X24TPI (TB-945A)	1
③	牙刀 1-1/8"X26TPI (TB-945B)	1
④	牙刀 1-1/4"X26TPI (TB-945C)	1
⑤	導塊 1" (TB-945D)	1
⑥	導塊 1-1/8" (TB-945E)	1
⑦	導塊 1-1/4" (TB-945F)	1
⑧	止付螺絲	2
⑨	握柄	2

## 2 組裝步驟

將握柄⑨依箭頭指示方向旋入主體①，即可完成組裝。

## 3 使用說明

1. 使用前叉立管攻牙組前，須配戴護目鏡，避免發生危險。
2. TB-1945用於延長前叉上的螺紋，請勿使用於無牙前叉。
3. 使用前請測量前叉尺寸，選擇正確的導塊與牙刀置入主體①中，確定牙刀上凹槽對上止付螺絲⑧，將兩側止付螺絲⑧輕輕鎖上（最大1.0Nm）（如圖一所示）。
  - 3-1. 牙刀(TB-945A)②適用1"前叉，並搭配導塊(TB-945D)⑤使用。
  - 3-2. 牙刀(TB-945B)③適用1-1/8"前叉，並搭配導塊(TB-945E)⑥使用。
  - 3-3. 牙刀(TB-945C)④適用1-1/4"前叉，並搭配導塊(TB-945F)⑦使用。
4. 加入切銷油於前叉管螺牙上（如圖二所示）。
5. 將前叉管攻牙組置於前叉立管，輕輕的將攻牙組以順時針方向旋入（請勿下壓）直到牙刀對上前叉上的螺紋。（如圖二所示）
6. 開始攻牙時請遵循前進兩圈退一圈的攻牙原則，並且不斷補充切削油。（選擇適當的切削油，避免傷害牙刀與螺紋）（如圖三所示）
7. 攻牙完成後逆時針旋轉將TB-1945取出。
8. 清除工具與前叉上的鐵屑與切削油，並塗上防銹油，確保牙刀與前叉立管的耐用性。

